



A  
Bray  
High  
Performance  
Company

# Flow-Tek®

A Subsidiary of BRAY INTERNATIONAL, Inc.

## 2 Piece Flanged Full Port Ball Valves: 1/2" - 12" ASME Class 150 & Class 300

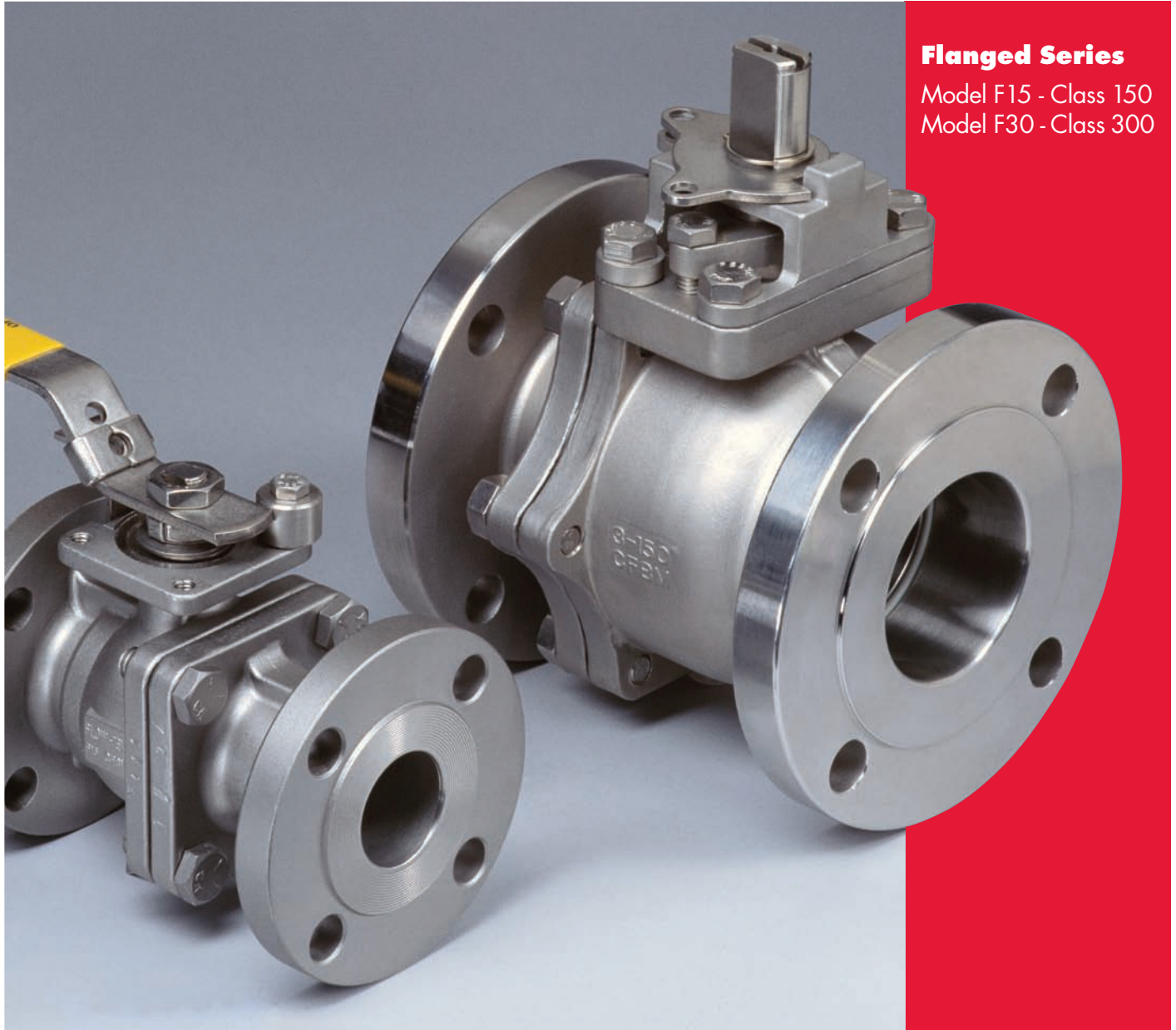

### Flanged Series

Model F15 - Class 150

Model F30 - Class 300

Flow-Tek's F15/F30 Flanged Series ball valves feature a floating ball design for low torque and increased cycle life. As standard, larger sized valves feature trunnion-type ball support. These rugged ball valves are ideal for industrial applications.

#### Fire Safe - Certified to API 607 4th Edition

Flanged Series valves with graphite stem seals have been thoroughly fire tested and meet these standards.

**Secure Mount** Flanged Series valves offer ease of automation due to an integrally cast actuator mounting pad which complies with ISO 5211 through 2" valve sizes.

#### Pressure Ratings

Model F15: ASME Class 150  
Model F30: ASME Class 300

#### Body Materials

Stainless Steel  
Carbon Steel  
Special Alloys upon request.



**Stem Seals** Flanged Series 1/2"–2" valves feature live-loaded, self-adjusting primary and secondary sealing. Utilizing bellville washers, the stem seal automatically adjusts to compensate for changes in temperature and normal wear. 2 1/2"–12" valves utilize an independent packing gland which can be easily adjusted without removing mounting hardware or operator. The packing gland is contoured to more uniformly distribute the load across the packing.

The primary seal is a combination of a thrust washer and a thrust washer protector. An adjustable

stem packing creates a secondary seal between the stem and body. The stem packing is composed of RPTFE V-rings as standard – graphite stem packing is standard on all Fire Safe valves.

**Ball** Flow-Tek balls are precision machined and mirror finished for bubble-tight shut off and less operating torque. As an added safety feature, a hole in the stem slot of each ball equalizes pressure between the body cavity and the line media flow.

**Body** 1/2"–4" valve bodies are investment cast and solution annealed/normalized for the highest quality and added strength. All body castings are marked with a foundry heat number for full traceability. Carbon Steel bodies are phosphate coated for increased corrosion resistance.

**Seat** Flow-Tek's seat design ensures bi-directional, bubble-tight sealing with low operating torque. All resilient seats feature relief slots or seat O.D. clearance to relieve pressure past the upstream seat, and positive preloading to ensure low pressure/vacuum sealing.



All manually operated valves feature a **Locking Device** to prevent accidental movement of ball position. Valves 1/2"–2" feature a safety trigger that locks the handle in the open or closed position. The handle lock can be bypassed, if needed, with a small bolt through the handle in the release position. On all sizes a **Padlock** can be added to secure the handle in position, preventing unwanted movement of the ball.

## Seat Selection

A wide range of seat materials are available to meet most applications. The standard seat is TFM 1600. Options include RPTFE, Stainless Steel/PTFE, UHMWPE, Virgin PTFE, PEEK, Tek-Fil® (carbon/graphite filled TFM), full metal seats and Cavity Fillers. PEEK seats offer high pressure/temperature capability. Tek-Fil® seats offer reduced torque in high temperature, high cycle, and steam service applications. TFM 1600 seats offer the exceptional chemical resistance of PTFE plus lower porosity and permeability, improved temperature range and reduced valve torques.

## Features

### Ball Support

For larger valve sizes, Flow-Tek's unique trunnion-type mounting supports the ball. This support maintains a constant seat profile, preventing seat damage and blow-by. The results are less seat wear, lower torque and a longer service life. The Flow-Tek ball support dramatically improves valve performance at a much lower cost than traditional trunnion mounting. This feature is standard on 10"-12" Model F15 and 6"-12" Model F30 valves.

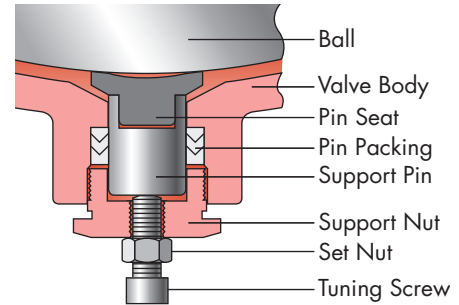

### Fire Safe: API 607-4 Certified

Flow-Tek's Flanged Series valves with graphite stem packing meet the highest fire safety standards under extreme conditions. In the event of a fire, after heat destroys the primary resilient seat, the ball makes contact with the secondary metal seat, forming a secure seal. The body seal, composed of

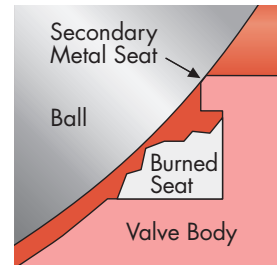

Stainless Steel and Graphite wound into a spiral, prevents external leakage. The Graphite stem rings prevent stem leakage.

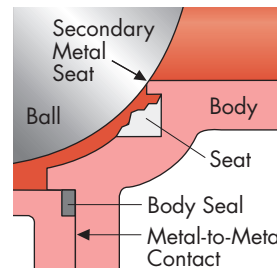

All valves have anti-static devices as standard – ball and stem are positively grounded.

Flow-Tek offers a **Media Containment Unit** as an option. This unit easily mounts to standard valves through 8" and adds an additional stem packing seal for difficult services.

# Technical Data

## Components & Materials

Carbon Steel bodies on Valve sizes 1/2" – 4" are Black Phosphate Coated.

All Stainless Steel bodies are solution annealed/normalized.

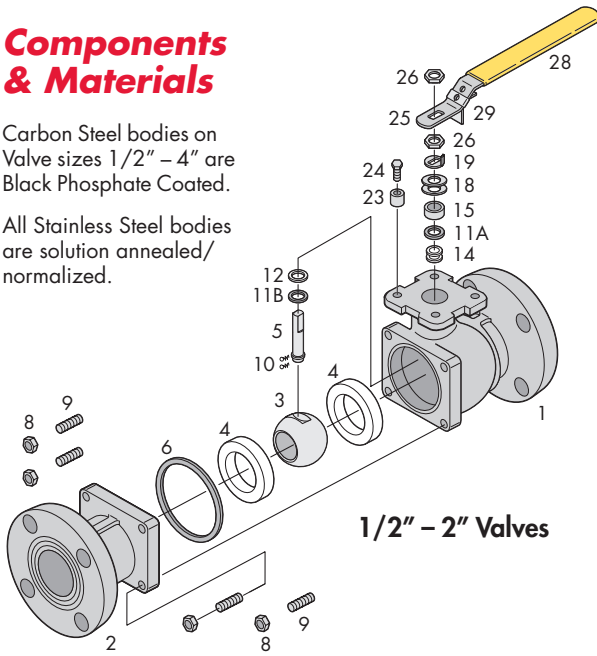

1/2" – 2" Valves

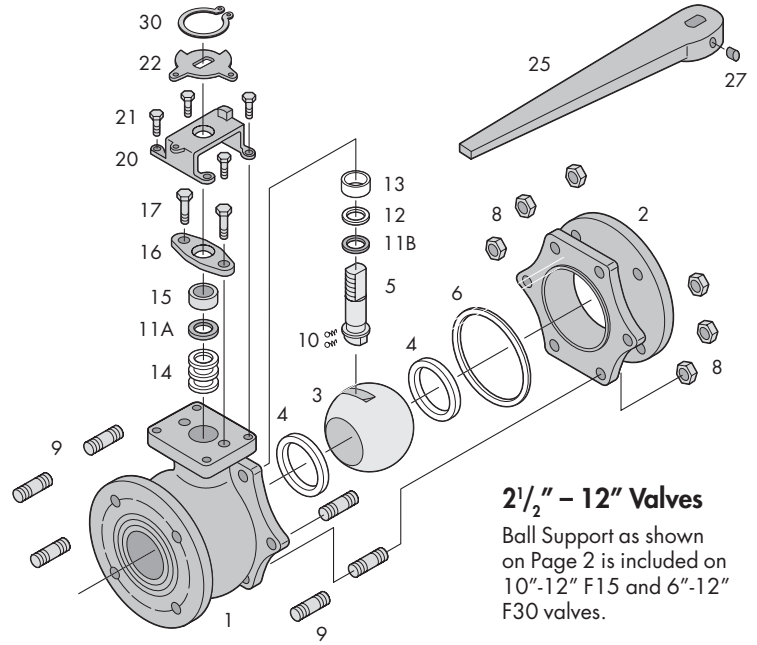

2 1/2" – 12" Valves

Ball Support as shown on Page 2 is included on 10"-12" F15 and 6"-12" F30 valves.

Item	Name	Stainless Steel	Carbon Steel	Qty.
1	Body	ASTM A351 Gr CF8M	ASTM A216 Gr WCB	1
2	End Cap	ASTM A351 Gr CF8M	ASTM A216 Gr WCB	1
3	Ball	ASTM A351 Gr CF8M	ASTM A351 Gr CF8M	1
4	Seat	TFM 1600	TFM 1600	2
5	Stem	ASTM A479 Type 316	ASTM A479 Type 316	1
6	Body Seal	Spiral Wound (316/Graphite)	Spiral Wound (316/Graphite)	1
8	Body Nut	ASTM A194 Gr 8	ASTM A194 2H	*
9	Body Stud	ASTM A193 B8	ASTM A193 B7	*
10	Anti-Static Device	SS304	SS304	2
11 A	Packing Protector	PEEK	PEEK	1
11 B	Thrust Washer Protector	PEEK	PEEK	1
12	Thrust Washer	Tek-Fil	Tek-Fil	1
13	Stem Bearing	15% RPTFE	15% RPTFE	1
14	Stem Packing	RPTFE/Graphite	RPTFE/Graphite	3/1
15	Packing Gland	ASTM A167 Type 304	ASTM A167 Type 304	1
16	Packing Follower	ASTM A351 Gr CF8M	ASTM A216 Gr WCB	1
17	Gland Bolt	SS304	SS304	2
18	Belleville Washer	SS301	SS301	2
19	Tab Lock Washer	SS304	SS304	1
20	Travel Stop Housing	CF8M	WCB	1
21	Housing Bolt	SS304	Alloy Steel	4
22	Travel Stop	SS304	Zinc Plated Carbon Steel	1
23	Travel Stop Sleeve	ASTM A167 Type 304	ASTM A167 Type 304	1
24	Travel Stop Bolt	SS304	SS304	1
25	Handle	SS304/**Ductile Iron	SS304/**Ductile Iron	1
26	Lock Nut	ASTM A167 Type 304	ASTM A167 Type 304	2
27	Handle Bolt	Carbon Steel	Carbon Steel	1
28	Handle Sleeve	Vinyl through 2"	Vinyl through 2"	1
29	Locking Device	SS304	SS304	1
30	Snap Ring	Nickel Plated Carbon Steel	Nickel Plated Carbon Steel	2

\*Quantity depends on valve size.

\*\* 2-1/2" and larger valves.

Flow-Tek offers the seat, body seal, thrust washer and stem packing as recommended spare parts. These parts are available as a packaged repair kit.

## Specifications

End Connections meet ASME Class 150/300. Flanges meet ASME B16.5 raised face. Face to Face Dimensions meet ASME B16.10 long pattern. All Valves meet ASME B16.34, API 608, & MSS-SP 72. All Valves are certified to API 607 4th Edition (with Graphite Stem Packing). NACE MR0175-Consult Factory.

All Valves are Hydrostatically Pressure Tested (Shell) and Air Pressure Tested (Seat) to the following in psi: Class 150: Shell 450 [CS] 425 [SS] Seat 80 Class 300: Shell 1125 [CS] 1100 [SS] Seat 80 Valves meet or exceed ASME Class VI shutoff.

## Pressure / Temperature

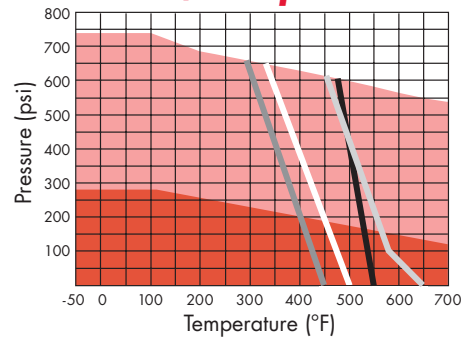

■ Class 150 Valve Bodies  
■ Class 300 Valve Bodies  
■ RPTFE    ■ PEEK  
■ Tek-Fil®     TFM 1600 & 50/50

**Note:** Carbon Steel valves limited to -20°F.

## Steam Service Pressure Ratings: WSP

Valve	TFM Seats PSI	TFM Seats °F	Tek-Fil Seats PSI	Tek-Fil Seats °F	PEEK Seats PSI	PEEK Seats °F
Class 150	150	365	190	450	170	500
Class 300	150	365	425	450	425	500

Vacuum Service to 29.9 inches Hg. gauge.

## MODEL F15 – Class 150

SIZE ins (mm)	A	øB	C	C1	D	E	øF	N	øS	øT	Cv	TORQUE * lbs-in (kg·Nm)	WEIGHT lbs. (kg.)
1/2	4.25	0.59	2.60	1.54	6.50	1.79	3.50		2.38	0.62	32	36	4
15	108.0	15.0	66.0	39.0	165.0	45.5	88.9	4	60.5	15.8	28	4	2
3/4	4.62	0.79	2.91	1.67	6.50	2.01	3.88		2.75	0.62	60	65	5
20	117.0	20.0	73.9	42.4	165.0	51.0	98.6	4	69.9	15.8	52	7	2
1	5.00	0.98	3.43	2.05	7.87	2.13	4.25		3.12	0.62	105	95	10
25	127.0	24.9	87.0	52.0	199.9	54.0	108.0	4	79.0	15.8	91	11	4.5
1-1/2	6.50	1.49	4.23	2.60	9.84	2.76	5.00		3.88	0.62	275	230	14
40	165.0	37.9	107.0	66.0	249.9	70.0	127.0	4	98.6	15.8	238	26	6
2	7.00	1.97	4.53	2.95	10.43	3.07	6.00		4.75	0.75	500	390	20.5
50	177.8	50.0	115.0	74.9	264.9	78.0	152.0	4	120.7	19.0	433	44	9
2-1/2	7.50	2.56	6.22	3.39	15.35	3.08	7.00		5.50	0.75	780	500	36
65	190.5	65.0	158.0	86.0	389.9	78.0	177.8	4	139.7	19.0	675	56	16
3	8.00	2.99	6.54	3.66	15.35	3.74	7.50		6.00	0.75	1,150	650	45
80	203.0	76.0	166.0	93.0	389.9	95.0	190.5	4	152.0	19.0	995	73	20
4	9.00	3.99	7.20	4.39	15.35	4.47	9.00		7.50	0.75	2,100	1,505	65
100	228.6	101.0	182.9	111.5	389.9	113.5	228.6	8	190.5	19.0	1,817	170	29.5
6	15.50	5.98	11.22	7.17	15.35	7.62	11.00		9.50	0.88	5,000	3,250	157
150	393.7	151.9	284.9	182.0	389.9	193.6	279.0	8	241.0	22.0	4,325	367	71
8	18.00	7.87	12.72	7.60	38.98	8.35	13.50		11.75	0.88	9,600	4,750	290
200	457.0	199.9	323.0	193.0	990.0	212.0	342.9	8	298.5	22.0	8,304	537	132
10	21.00	9.84	13.70	9.88	38.98	10.47	16.00		14.25	1.00	15,000	13,700	500
250	533.0	249.9	348.0	251.0	990.0	265.9	406.0	12	362.0	25.0	12,975	1,548	227
12	24.00	11.81	15.28	11.46	38.98	12.01	19.00		17.00	1.00	21,000	19,700	700
300	609.6	300.0	388.0	291.0	990.0	305.0	482.6	12	431.8	25.0	18,165	2,226	318

Face to Face dimensions meet ASME B16.10 long pattern.

\*Torque at maximum rated pressure, clean water, TFM 1600 seating material. Other seat materials exhibit different torques.

Please refer to TB 1005 for specific torques.

## MODEL F30 – Class 300

SIZE ins (mm)	A	øB	C	C1	D	E	øF	N	øS	øT	Cv	TORQUE * lbs-in (kg·Nm)	WEIGHT lbs. (kg.)
1/2	5.50	0.59	2.60	1.57	6.50	2.44	3.75		2.62	0.62	32	40	5
15	139.7	15.0	66.0	39.9	165.0	62.0	95.0	4	66.6	15.8	28	5	2
3/4	6.00	0.79	2.91	1.67	6.50	2.72	4.62		3.25	0.75	60	70	7
20	152.0	20.0	73.9	42.0	165.0	69.0	117.0	4	82.6	19.0	52	8	3
1	6.50	0.98	3.43	2.05	7.87	2.91	4.88		3.50	0.75	105	108	10
25	165.0	24.9	87.0	52.0	199.9	73.9	124.0	4	88.9	19.0	91	12	5
1-1/2	7.50	1.49	4.23	2.60	9.84	3.27	6.12		4.50	0.88	275	270	19
40	190.5	37.9	107.0	66.0	249.9	83.0	155.5	4	114.0	22.0	238	31	9
2	8.50	1.97	4.53	2.95	10.43	3.94	6.50		5.00	0.75	500	445	25
50	215.9	50.0	115.0	74.9	264.9	100.0	165.0	8	127.0	19.0	433	50	11
2-1/2	9.50	2.56	6.22	3.39	15.35	4.18	7.50		5.88	0.88	780	600	44
65	241.0	65.0	158.0	86.0	389.9	106.0	190.5	8	149.0	22.0	675	68	20
3	11.12	2.99	6.54	3.72	15.35	5.57	8.25		6.62	0.88	1,150	850	61
80	282.5	76.0	166.0	94.5	389.9	141.5	209.6	8	168.0	22.0	995	96	27.7
4	12.00	3.99	7.20	4.35	15.35	5.96	10.00		7.88	0.88	2,100	2,600	96
100	304.8	101.0	182.9	110.5	389.9	151.0	254.0	8	200.0	22.0	1,817	294	44
6	15.88	5.98	11.22	7.19	38.98	7.60	12.50		10.62	0.88	5,000	5,300	243
150	403.0	151.9	285.0	182.6	990.0	193.0	317.5	12	269.8	22.0	4,325	599	110
8	19.75	7.87	12.72	8.64	38.98	9.33	15.00		13.00	1.00	9,600	7,600	430
200	501.7	199.9	323.0	219.5	990.0	237.0	381.0	12	330.0	25.0	8,304	859	195
10	22.38	9.84	13.70	9.69	38.98	11.18	17.50		15.25	1.12	15,000	17,800	610
250	568.5	249.9	348.0	246.0	990.0	284.0	444.5	16	387.0	28.5	12,975	2,011	277
12	25.50	11.81	15.28	11.26	38.98	12.80	20.50		17.75	1.25	21,000	24,800	950
300	647.7	300.0	388.0	286.0	990.0	325.0	520.7	16	450.9	31.8	18,165	2,802	431

## SECURE MOUNT

SIZE ins (mm)	H	J	F0	BC DIA.	K	L	M	øP	U UNC
1/2	1.17	1.17	F04	1.65	0.31	0.61	0.25	0.37	#10-24
15	29.7	29.7	F04	41.9	7.9	15.5	6.0	9.4	#10-24
3/4	1.17	1.17	F04	1.65	0.31	0.61	0.25	0.37	#10-24
20	29.7	29.7	F04	41.9	7.9	15.5	6.0	9.4	#10-24
1	1.39	1.39	F05	1.97	0.43	0.82	0.31	0.43	1/4-20
25	35.0	35.0	F05	50.0	10.9	20.8	7.9	10.9	1/4-20
1-1/2	1.95	1.95	F07	2.76	0.55	0.95	0.37	0.62	5/16-18
40	49.5	49.5	F07	70.0	14.0	24.0	9.0	15.8	5/16-18
2	1.95	1.95	F07	2.76	0.55	0.95	0.37	0.62	5/16-18
50	49.5	49.5	F07	70.0	14.0	24.0	9.0	15.8	5/16-18
2-1/2-4	3.54	1.87	F10	—	1.75	3.10	0.67	1.10	1/2-13
65-100	89.9	47.5	F10	—	44.5	78.7	17.0	27.9	1/2-13
6	3.37	3.37	F12	4.77	1.61	3.58	1.02	1.71	1/2-13
150	85.6	85.6	F12	121.0	40.9	90.9	25.9	43.0	1/2-13
8 <sup>1</sup>	3.37	3.37	F12	4.77	2.13 <sup>1</sup>	3.58 <sup>1</sup>	1.02	1.71	1/2-13
200	85.6	85.6	F12	121.0	54.0	90.9	25.9	43.0	1/2-13
10-12 <sup>2</sup>	4.53	4.53	F16	6.40	2.15	3.86 <sup>2</sup>	1.38	1.97 <sup>2</sup>	5/8-11
250-300	115.0	115.0	F16	162.6	54.6	98.0	35.0	50.0	5/8-11

<sup>1</sup> For 8" F30: K=1.61, L=3.42

<sup>2</sup> For 10" F30: L=3.82, P=2.165

NOTE 1: Ball Support as shown on Page 2 is included on 10"-12" F15 and 6"-12" F30 valves.

NOTE 2: 2 1/2", 3" & 4" valves feature a NAMUR stem slot for ease of limit switch mounting.

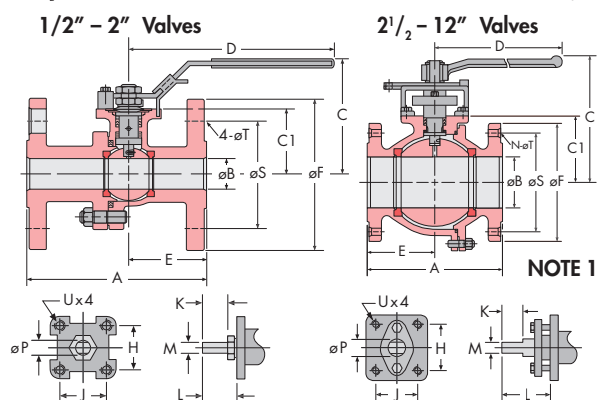

# Flow-Tek®

A Subsidiary of BRAY INTERNATIONAL, Inc.  
8323 N. Eldridge Pkwy #100 Houston, Texas 77041  
832.912.2300 Fax: 832.912.2301  
www.flow-tek.com

All statements, technical information, and recommendations in this bulletin are for general use only. Consult Flow-Tek representatives or factory for the specific requirements and material selection for your intended application. The right to change or modify product design or product without prior notice is reserved.

Flow-Tek® is a registered trademark of Flow-Tek, Inc.  
© 2010 Flow-Tek, Inc.  
F-2400\_EN\_F15-30\_2010-10