

## Specialist Mounting Kit Designs

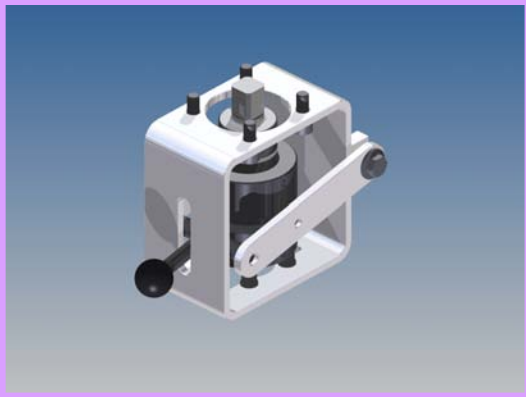

With 140 years experience in fluid handling, Heap & Partners utilise their vast knowledge and expertise to provide innovative ideas and design solutions for a range of customer specific problems.

One such solution was required by FMC Corporation (UK), Lithium Division who had a specific problem on pneumatically actuated ball valves that were being used on Butyl Lithium tankers.



They had to ensure the integrity of the actuators that were being used on safety duties and required a solution to enable them to periodically perform a full functional test whilst in service but without operating the valve.



Heap & Partners provided a new mounting kit design that enabled them to disengage the actuator from the valve and allowed the actuator to be stroked between the open and closed position to ensure correct operation without moving the valve.