



I Application

The blenders are used to mix solids in liquids.

In the food-processing industry, they provide a perfect solution for reconstituting powdered milk, making syrups, preparing brines, etc.

They can also be a solution to preparing solid-liquid mixtures in the pharmaceutical, cosmetics and chemical industries.

I Operating principle

The blender basically consists of a casing and a centrifugal pump impeller which are mounted vertically. The suction side has a double-wall pipe that keeps the inlet of solids separate from that of liquids, thus avoiding the formation of lumps before the material enters the casing.

The liquid enters the mixing chamber at a high speed, thereby creating a vacuum at the center of the impeller, which causes the suction of the solids. The fall of the solids can be regulated by means of a valve situated at the bottom of the hopper.

I Design and features

Simple and versatile assembly for quick and homogeneous mixing of a great variety of solids without contact with the air.

Complete mixing with recirculation of the material.

In some applications, it can be used in line, without recirculation.

Sanitary design.

Easy assembly and disassembly by Clamp connections.

Cleaning can be carried out without disassembling the unit.

Sanitary single mechanical seal.

Standard hopper of 40° for M-226 and 50° for M-440.

I Materials

Parts in contact with the product: AISI 316L

Gaskets: EPDM according to FDA 177.2600

Mechanical seal: C/ St.St / EPDM

Internal surface finish: mirror polish, $Ra \leq 0.8 \mu m$

External surface finish: bright polish

I Options

Double flushed seal.

Double pressurised seal.

Connections: DIN, SMS.

Pneumatically actuated valve.

60° hopper.

Screen in the mixing chamber.

Drainage.

Internal surface finish: $Ra \leq 0.5 \mu m$.

ATEX version available.



I Technical specifications

Blender model	M-226	M-440
Blender motor	4 kW 3000 rpm	11 kW 3000 rpm
Suctions	CLAMP 1½"	CLAMP 3"
Discharge	CLAMP 2"	CLAMP 3"
Liquid flow	up to 33.000 l/h	up to 65.000 l/h
Solid suction*	3000 [kg/h]	9000 [kg/h]
Hopper capacity	45 l	65 l

* The quantity of the product suctioned depends on its properties and the features of the installation. Please, contact INOXPA technical department to select auxiliary pumps.



It is important to keep low pressure at the suction and at the discharge sides of the blender. Avoid cavitation. Thus a feeding pump must be provided only for the applications that really require it (considerable pressure drops at the suction side, high viscosity products, etc.), please, keep in mind that the suction capacity will decrease.

When discharge pressure is high, a centrifugal pump needs to be fitted to the discharge side of the blender.

For viscosities above 500 cP, the feeding pump and the discharge pump must be positive displacement pumps.

I Applications

Preparation of sugar syrup, sorbitol, glucose, lactose and derivatives.

Reconstitution of powdered milk.

Dissolution of cocoa and/or sugar in milk.

Reconstitution of powdered whey.

Preparation of flour and starch slurries.

Preparation of brines.

Pre-mixtures of yogurt and other milk-based desserts.

Dissolution of bentonites for wine filtering.

Dissolution of casein and caseinates in the cheese-making industry.

Preparation of pesticides and fertilizers.

I Switchboard

The mixers can be provided with a switchboard for operation and protection of the equipment.

The basic functions of the standard switchboard are the following:

- Stop / start
- Emergency stop
- Motor protection
- Star-triangle start for 11 kW motors

I Options

The following control components can be added:

- Pneumatic valve
- High- and low-level sensors
- Vibrator (pneumatic or electric)



I Hopper vibrator

We offer the option of installing a vibrator to the hopper to facilitate the complete discharge of the solids such as very fine powders.

The vibration allows keeping the flow of solids until the hopper is completely empty, thus avoiding residual materials from being left attached to the walls of the hopper.

If substantial vibration is required, the mixer will be adapted to operate under the relevant conditions. This adaptation is made by means of an anti-vibration support for the hopper and an elastic coupling.



I Types of vibrators

PNEUMATIC VIBRATOR: The vibration is produced by means of a roller rolling on steel grooves.

The frequency of vibration is changed by regulating the entry of air into the vibrator.

ELECTRIC VIBRATOR: The motor drives masses situated off-center on each side of the rotating shaft in order to provide the required vibration.

The rotating shaft generates centrifugal forces that can be modified by changing the masses.

I Solid detection sensor

Due to the high degree of automation of the processes, it is important that all the variables relevant to the process are controlled. In order to cover this need, we offer the possibility of adding one or two solid detection sensors to the hopper. These sensors provide a signal to indicate low and/or high level in the hopper.

The low level signal can be used to control the valve in the lower part of the hopper in order to avoid the entry of air into the mixing chamber.

The high level sensor can be used to control a solid feeding unit.



I Type of sensor

The type of sensor used is "vibrating plates".

By means of an electronic circuit, the plates vibrate at a given frequency.

This frequency varies with the presence / absence of solids, and the variation is detected by a control circuit which changes the status of the output signal accordingly.

I Features

- Plates of reduced dimensions
- BSP 3/4" thread
- Parts in contact with the product in AISI-316

I Dimensions: blender M-226

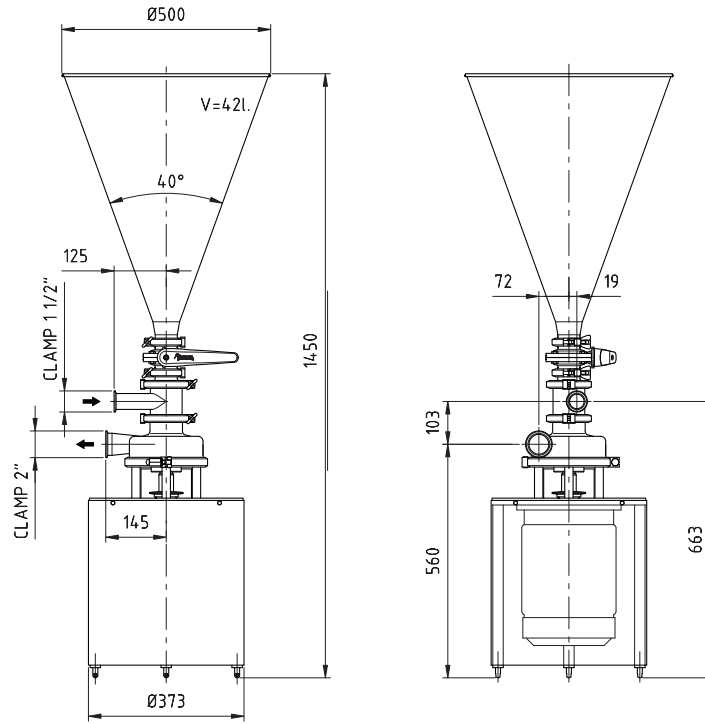

I Dimensions: blender M-440

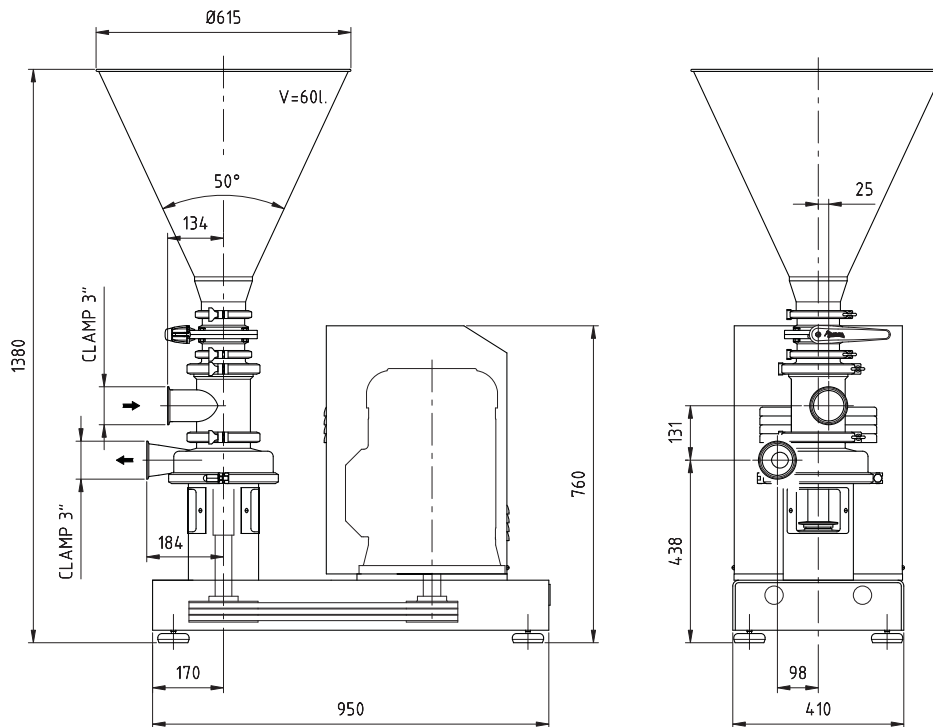

The information is for guidance only. We reserve the right to modify any material or feature without notice in advance. Photos are not binding. For further information, please, consult our web site. www.inoxpa.com

